



BAPI-Stat "Quantum" Temperature Sensor with Display, Button Setpoint, Fan or System Mode Control

Installation & Operating Instructions

41011_ins_quantum_btn_temp_display

rev. 07/22/20

Product Identification and Overview

The BAPI-Stat "Quantum" style room temperature sensor features a large format LCD and pushbutton setpoint adjustment. Additional options include pushbutton override, fan speed and mode adjustment.

The setpoint is available as a resistance or voltage output. The override is a momentary closure signal that can be configured in parallel with the sensor or setpoint, or as a separate momentary output.

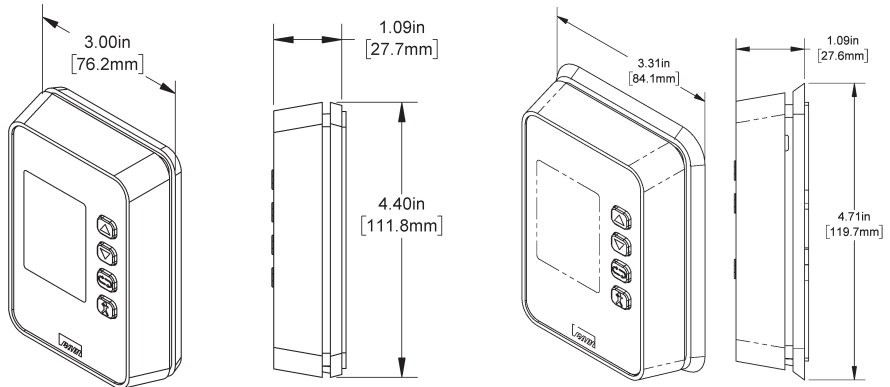

Included Screw Pack

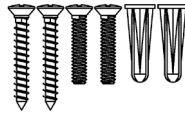

Fig. 1: BAPI-Stat "Quantum" Temperature Sensor (standard mounting base at left and 60mm mounting base for European wall boxes with 60mm mounting centers at right)

Mounting

JUNCTION BOX

1. Pull the wire through the wall and out of the junction box, leaving about 6" free. Pull the wire through the hole in the base plate. Secure the base to the box using the #6-32x1/2" mounting screws provided.
3. Terminate the unit according to the guidelines in the **Termination** section.
4. Attach Cover by latching it to the top of the base, rotating the cover down and snapping it into place.
5. Secure the cover by backing out the lock-down screws using a 1/16" Allen wrench until they are flush with the bottom of the cover.

DRYWALL MOUNTING

1. Place the base plate against the wall where you want to mount the sensor. Mark out the two mounting holes and the area where the wires will come through the wall.
2. Drill two 3/16" holes in the center of each marked mounting hole. Insert a drywall anchor into each hole.
3. Drill one 1/2" hole in the middle of the marked wiring area. Pull the wire through the wall and out the 1/2" hole, leaving about 6" free. Pull the wire through the hole in the base plate.
4. Secure the base to the drywall anchors using the #6 x 1 inch mounting screws provided.
5. Terminate the unit according to the guidelines in the **Termination** section.
6. Attach cover by latching it to the top of the base, rotating the cover down and snapping it into place. Secure the cover by backing out the lock-down screws using a 1/16" Allen wrench until they are flush with the bottom of the cover.

NOTE: The mixing of room air and air from within the wall cavity can lead to erroneous readings, condensation and failure of the sensor. To prevent this, plug the conduit hole in the junction box with insulation.

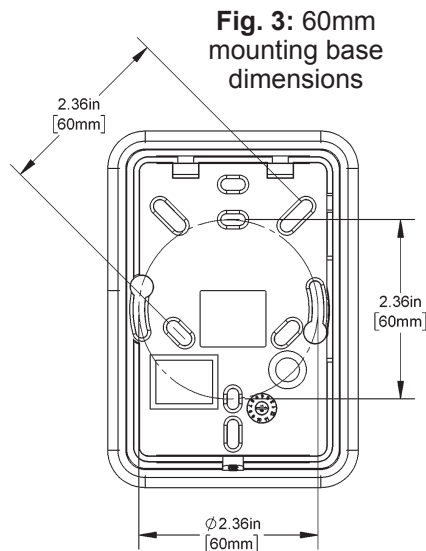

Fig. 3: 60mm mounting base dimensions

Fig. 2: J-Box mounting with standard base

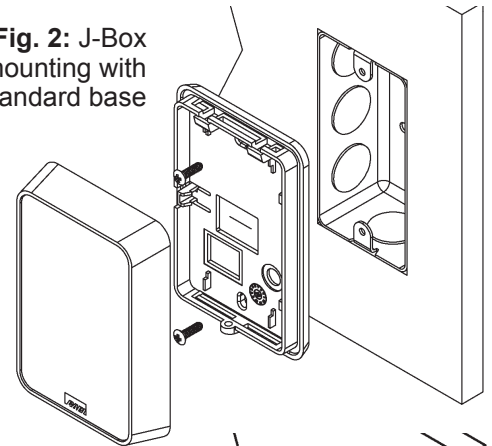
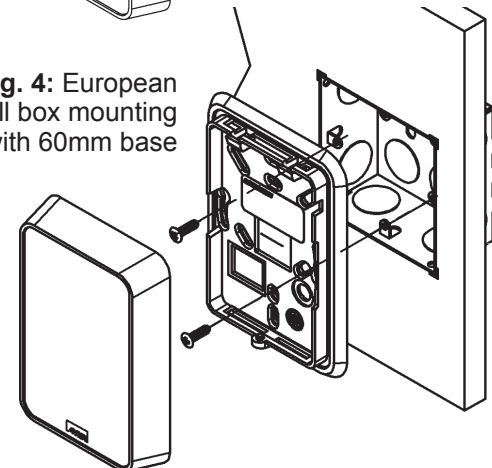

Fig. 4: European wall box mounting with 60mm base





BAPI-Stat "Quantum" Temperature Sensor with Display, Button Setpoint, Fan or System Mode Control

Installation & Operating Instructions

41011_ins_quantum_btn_temp_display

rev. 07/22/20

Termination

BAPI recommends using twisted pair of at least 22AWG and sealant filled connectors for all wire connections. Larger gauge wire may be required for long runs. All wiring must comply with the National Electric Code (NEC) and local codes. Do NOT run this device's wiring in the same conduit as AC power wiring. BAPI's tests show fluctuating and inaccurate signals are possible when AC power wiring is in the same conduit as the signal lines. If you are experiencing any of these difficulties, please contact your BAPI representative.



BAPI recommends wiring the product with power disconnected. Proper supply voltage, polarity and wiring connections are important to a successful installation. Not observing these recommendations may damage the product and void the warranty.

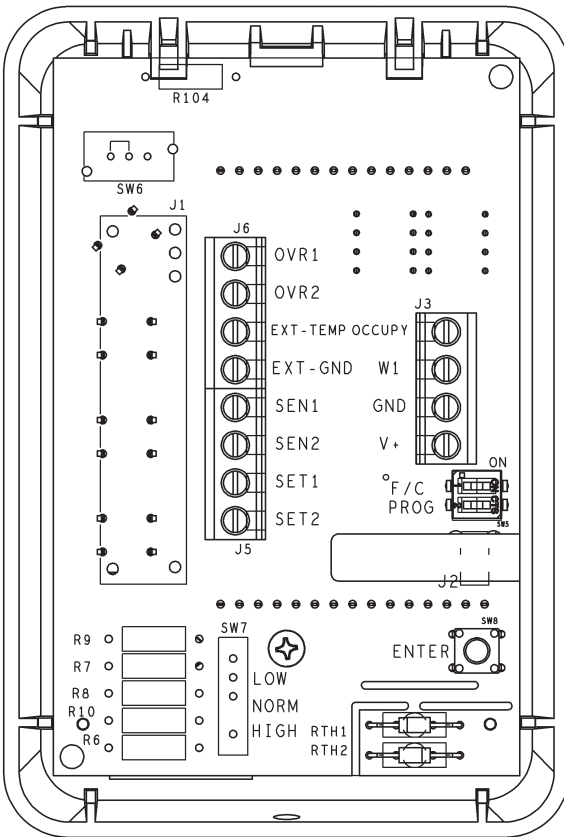

Fig. 5: BAPI-Stat "Quantum" Circuit Board

TERMINAL

DESCRIPTION

- GND..... Power Supply Ground (Common to the controller)
- V+ Power Supply Hot (See specs for voltage details)
- W1 Fan Speed/System Mode (Resistive Output)
- OCCUPY BAPI-Man Occ/Un-Occ indicator Input. Ground terminal to fill in the BAPI-Man icon for Occupied.
- SEN1 & SEN2 Sensor output per order (resistive). No polarity. *If the unit is a common ground configuration, see "Grounding Note" below.
- SET1 & SET2 A) Setpoint output per order (resistive). *If the unit is a common ground configuration, see "Grounding Note" below.
 B) Setpoint output per order (voltage). SET1 is "+", SET2 is "-".
- OVR1 & OVR2..... Override Output (Dry contact) if unit is ordered with Override as a Separate Output (-J). The override can also be ordered as a momentary shunt across the sensor terminals SEN1 & SEN2 (-N) or as a momentary shunt across the setpoint terminals SET1 & SET2 (-P). *If the unit is a common ground configuration, see "Grounding Note" below.

EXT-TEMP & EXT-GND.. Remote sensor terminals. No polarity. *If the unit is a common ground configuration, see "Grounding Note" below. To use these terminals, a 10K-2 thermistor sensor must be ordered separately and the temperature value from this sensor will be displayed on the LCD but will not be sent to the controller. Max wire distance for the external sensor is 25 feet.

*Grounding Note:

Common Ground or Differential Ground configurations are selected per order (Common Ground is default). The Differential Ground configuration indicates that SEN2, SET2, OVR2 and EXT-GND must all be wired separately (No internal common connection). The Common Ground configuration indicates that SEN2, SET2, OVR2 and EXT-GND are connected to GND internally (All internally common).

Specifications subject to change without notice.

Optional Communication Jack Wiring

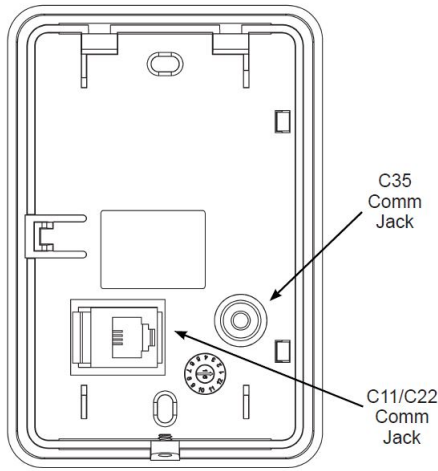
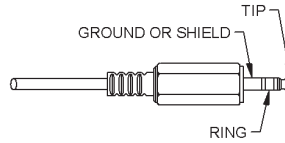

Fig. 6: Back Plate Comm. Jack Locations

Fig. 7: C35L Comm. Jack (3.5mm plug shown for clarity)



C35L Comm. Jack Wiring	
Location	WIRE COLOR
Ground	Black
Tip	White
Ring	Red

Fig. 8: C11/C22 Comm. Jack

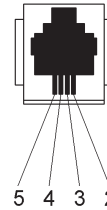

C11L/C22L Comm. Jack Wiring	
PIN #	WIRE COLOR
1	Not Connected
2	Black
3	Red
4	Yellow
5	Green
6	Not Connected

Optional Test and Balance Switch (SW7)

On the Test and Balance Switch, the NORM position allows the real sensor to be monitored. The HIGH position forces the output to a very hot reading and the LOW position forces a very cold reading (see Table below).

Test and Balance Switch (SW7)

LOW: Sets the sensor value low

NORM: Sensor operates normally

HIGH: Sets the sensor value high

Sensor Type	Low Temp (40° F) Resistance Value	High Temp (105° F) Resistance Value
1000Ω RTD	1.02KΩ (41.20°F)	1.15KΩ (101.5°F)
3000Ω Thermistor	7.87KΩ (39.8°F)	1.5KΩ (106.8°F)
10K-2 Thermistor	30.1KΩ (34.9°F)	4.75Ω (109.1°F)
10K-3 Thermistor	26.7KΩ (35.9°F)	5.11KΩ (108.4°F)
10K-3(11K) Thermistor	7.32KΩ (43.7°F)	3.65Ω (105.2°F)

Optional Fan Speed and System Mode Control

The unit is available with optional Fan Speed and System Mode Control. The resistive outputs for the various options is shown in the table at right. The option is selected at the time of order and the resistive value is output to the W1 terminal.

Option	Heat/Auto	Off /Auto	Cool/Auto	Heat/On	Off/On	Cool/On
HCF	5KΩ	10KΩ	15KΩ	20KΩ	25KΩ	30KΩ
H01	0Ω	2KΩ	4KΩ	6KΩ	8KΩ	10KΩ

Option	OFF	AUTO	LO	MED	HI	ON
XLD	5KΩ	10KΩ	15KΩ	20KΩ	25KΩ	
X01	4.89KΩ	2.33KΩ	10.63KΩ	13.24KΩ	16.33K	
X02	2KΩ	4KΩ	6KΩ	8KΩ	10KΩ	
X03	5KΩ	10KΩ				15KΩ
X05	4.89KΩ	2.33KΩ				15.8KΩ
X06	6.5KΩ		8.5KΩ	10.5KΩ	12KΩ	
X07	5KΩ					15KΩ
X08	12.68KΩ	11.86KΩ				13.86KΩ

Specifications subject to change without notice.

Front Panel & Control Descriptions

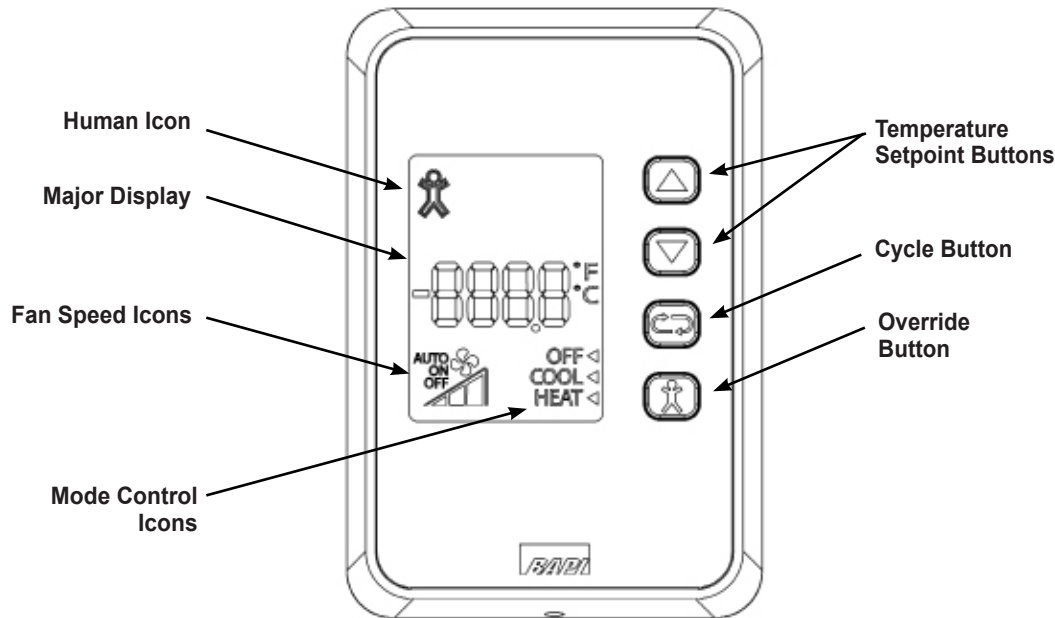

Fig. 9: BAPI-Stat “Quantum” with Display, Button Setpoint, Override, and Fan/System Mode Control.

BAPI-Stat “Quantum” sensor comes with a display, pushbutton setpoint adjustment, optional override, and optional fan speed control or system mode control.

Temperature:

Displayed in Fahrenheit or Celsius in the major display. (Field adjustable via the “F/C” switch on DIP Switch SW5.)



Temperature Setpoint Pushbuttons:

Pressing the Up/Down buttons to change the setpoint will display the setpoint in the major display. The setpoint temperature display will flash the digits indicating that the setpoint is being changed.



Cycle Button:

Pressing the cycle button will adjust the W1 output and the LCD icons for system control (OFF, COOL, HEAT, AUTO and ON) and the LCD icons for fan speed (AUTO, ON, OFF, Blades and Bars). Depending on the type of fan speed or mode control control that the unit has, some of the icons may not be displayed on the LCD.



Override Button:

When the override button is pressed on display units, the Human Icon Icon will display (Fig 10). A dry resistance of less than 15Ω appears across the override output.

Note: The unit must receive a confirmation (ground) signal on the “OCCUPY” terminal for the Human Icon to remain visible on the screen. Pressing the Override button will light the Human Icon icon; however, if no confirmation signal is received, then the Human Icon will go blank (disappear) after 5 seconds.

Upon receiving a first confirmation (ground) signal on the “OCCUPY” terminal, the Human Icon will show occupied (Solid). The Human Icon will then show unoccupied (Hollow) whenever the confirmation signal is removed and occupied when the signal is returned. The only way to blank the Human Icon from the display after it has received a first confirmation signal is to cycle power.

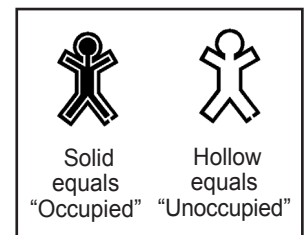

Fig. 10: Human Icon

Specifications subject to change without notice.



BAPI-Stat “Quantum” Temperature Sensor with Display, Button Setpoint, Fan or System Mode Control

Installation & Operating Instructions

41011_ins_quantum_btn_temp_display

rev. 07/22/20

Optional Technician Adjustments

The unit is shipped ready to install. The following Setup or Program Menu Changes are available if the installer decides to change the factory settings.

ENTERING PROGRAM MODE TO ADJUST PARAMETERS (see Figs 11-13 for adjustment tools)

1. Power unit and set DIP Switch SW5 #2 (PROG) to ON (right). The LCD will show a page number (P1-P9). P1-P9 will flash to indicate that display parameter can be adjusted.
2. The Setpoint Up/Down buttons on the front of the unit are used to scroll up and down through pages and adjusting the page parameters.
3. Push Switch SW8 as “Enter” to switch between page number and adjusting the page parameter.
4. After a page parameter has been adjusted, push Switch SW8 to confirm the change.
5. To exit Program Mode, Set DIP Switch SW5 #2 (PROG) to OFF (left).

Note: DIP Switch SW5 #1 (°F/C) can be used to switch the display between °F and °C.

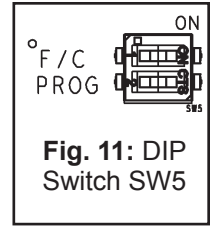

Fig. 11: DIP Switch SW5

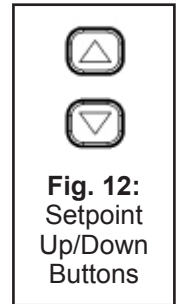

Fig. 12: Setpoint Up/Down Buttons

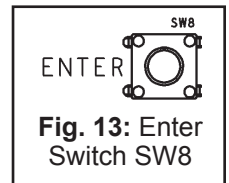

Fig. 13: Enter Switch SW8

Programming Pages												
Parameter	Page	Adjustment										
Temperature Offset	P1	±5° in 0.1° increments (Temp offset only adjusts display)										
Setpoint Lockout	P2	<table border="1"> <thead> <tr> <th>Item</th> <th>Display Action</th> </tr> </thead> <tbody> <tr> <td>0</td> <td>Setpoint Enabled</td> </tr> <tr> <td>1</td> <td>Setpoint Disabled (pushbutton only): Display shows setpoint when activated, but can't be changed</td> </tr> <tr> <td>2</td> <td>Setpoint Display Only: Shows setpoint only, does not display local temperature</td> </tr> <tr> <td>3</td> <td>Setpoint Not Displayed: Setpoint can be changed, but will not display</td> </tr> </tbody> </table>	Item	Display Action	0	Setpoint Enabled	1	Setpoint Disabled (pushbutton only): Display shows setpoint when activated, but can't be changed	2	Setpoint Display Only: Shows setpoint only, does not display local temperature	3	Setpoint Not Displayed: Setpoint can be changed, but will not display
		Item	Display Action									
		0	Setpoint Enabled									
		1	Setpoint Disabled (pushbutton only): Display shows setpoint when activated, but can't be changed									
2	Setpoint Display Only: Shows setpoint only, does not display local temperature											
3	Setpoint Not Displayed: Setpoint can be changed, but will not display											
Temperature Display	P3	<table border="1"> <thead> <tr> <th>Item</th> <th>Display Action</th> </tr> </thead> <tbody> <tr> <td>0</td> <td>Display in whole digits</td> </tr> <tr> <td>1</td> <td>Display in 0.5° increments, °F and °C</td> </tr> <tr> <td>2</td> <td>Display in 0.1° increments, °F and °C</td> </tr> </tbody> </table>	Item	Display Action	0	Display in whole digits	1	Display in 0.5° increments, °F and °C	2	Display in 0.1° increments, °F and °C		
		Item	Display Action									
		0	Display in whole digits									
1	Display in 0.5° increments, °F and °C											
2	Display in 0.1° increments, °F and °C											
Temperature Setpoint Display Low	P4	Adjust the Low Temperature of the setpoint range										
Temperature Setpoint Display High	P5	Adjust the High Temperature of the setpoint range										
Temperature Setpoint Output Low	P6	Shows Low Setpoint Output (Read Only. Displayed in 10 ohm resolution)										
Temperature Setpoint Output High	P7	Shows High Setpoint Output (Read Only. Displayed in 10 ohm resolution)										
Temperature Setpoint Value	P8	Shows temperature setpoint value (Ready Only)										
User Fan/Mode Setpoint	P9	Shows Fan/Mode setpoint on units configured with Mode/Setpoint (Ready Only. Pushbutton only. Major display shows 0)										

Specifications subject to change without notice.



BAPI-Stat “Quantum” Temperature Sensor with Display, Button Setpoint, Fan or System Mode Control

Installation & Operating Instructions

41011_ins_quantum_btn_temp_display

rev. 07/22/20

General Diagnostics

POSSIBLE PROBLEM:

Temperature reading is incorrect

Setpoint reading is incorrect

Override is not working correctly

Fan Mode not correct

POSSIBLE SOLUTIONS:

- Verify that the input is set up correctly in the controller’s and building automation software.
- Check wiring for proper termination and check for opens or shorts.
- Check for corrosion at either the controller or the sensor. Clean off the corrosion, re-strip the interconnecting wire and reapply the connection. In extreme cases, replace the controller, interconnecting wire and/or sensor.
- Label the terminals at the sensor end and the controller end. Disconnect the interconnecting wires from the controller and the sensor. With the wires separated at both ends, measure the resistance from wire-to-wire with a multimeter. The meter should read greater than 10 Meg-ohms, open or OL depending on the meter you have. Short the interconnecting wires together at one end. Go to the other end and measure the resistance from wire-to-wire with a multimeter. The meter should read less than 10 ohms (22 gauge or larger, 250 feet or less). If either test fails, replace the wire.
- Measure the physical temperature at the temperature sensor’s location using an accurate temperature standard. Disconnect the temperature sensor wires and measure the temperature sensor’s resistance across the sensor output pins with an ohmmeter. Compare the temperature sensor’s resistance to the appropriate temperature sensor table on the BAPI website. If the measured resistance is different from the temperature table by more than 5% call BAPI technical support. Find BAPI’s website at www.bapihvac.com; click on “Resource Library” and “Sensor Specs” then click on the type of sensor you have. Don’t forget to reconnect the wires.
- If the unit has a Test and Balance switch, make sure it is in the correct position.
- Make sure that the setpoint output is correct. Remove the setpoint output wire and check the output for the correct resistance or voltage output. See the product label for your specific range.
- Verify that the resistance across the override output is less than 15 ohms when the override is pushed.
- Make sure that the fan mode output is correct. Remove the fan mode output wire and check the output for the correct resistance. See the product label for your specific range and compare it to the resistance chart at the bottom of page 3. Don’t forget to reconnect the wire.

Specifications

Power for 24VDC Power Units:

0 to 5 VDC Setpoint:..... 9 to 40 VDC (24 VDC nominal)
 0 to 10 VDC Setpoint:.... 15 to 40 VDC (24 VDC nominal)
 Resistive Setpoint:..... 9 to 40 VDC (24 VDC nominal)
 Any Allowed Setpoint:... 15 to 28 VAC (24 VAC nominal)
 Note: AC power requires a separate pair of shielded wires

Power Consumption: 13 mA max DC; .32 VA max AC

Wiring: 22 to 16AWG

Mounting: Standard 2”x4” junction box, European junction box or drywall mount (screws provided)

Outputs:

Temperature: Thermistor or RTD
 Temperature Setpoint: Resistive or Voltage
 Fan/System Control: Resistive

Inputs: Dry contact (24V, <1mA)

Occupied: OCCUPY terminal “Grounded”

Unoccupied: OCCUPY terminal “Open to Ground”

External Sensor: 10K-2 thermistor,
 Purchased separately,
 Wired 25’ max from sensor

Enclosure Material: ABS Plastic, UL94V-0

Environmental Ambient:

Temperature: 32 to 122°F (0 to 50°C)
 Humidity: 0 to 95% RH Non-condensing
 Storage: 32 to 185°F (0 to 85°C)

Agency: RoHS

Specifications subject to change without notice.