



## SZ1018

### Modulating Zone Thermostat



## Description

The SZ1018 are specifically designed for the Superzone Commercial Zoning System (Superzone CZS). The SZ1018 have a 7-day time clock and is designed for applications with modulating zone damper and reheat or peripheral heat.

## Features

- Stand-alone or network operation
- 7-day time clock
- Discharge air sensor input with high and low limits and reset
- Outdoor air sensor input with heating & cooling lockout
- Offers up to two stages for heating and/or cooling and the outputs for zone damper and reheat
- Adjustable delay on powerup for soft starts
- P+I control option
- Smart Recovery
- No backup battery required
- Built-in HVAC equipment protection
- 32 character LCD display
- Six LEDs for status monitoring
- Remote room sensing capability
- User setpoint adjustment limits
- Local and remote override capability
- System and fan switching with access lockouts
- Fan interlock safety option
- Filter service input and indication
- Equipment monitoring inputs and indication
- External time clock input
- Energy management input for setpoint shift
- Access to programming or schedule may be locked out or limited with the use of an access code
- Fahrenheit or Celsius temperature display
- Digital or analog changeover

## Contents

Description . . . . .	1
Features . . . . .	1
Mounting . . . . .	1
Wiring . . . . .	2
Setup . . . . .	3
Programming . . . . .	4
Setting Clock & Schedule . . . . .	7
Operation . . . . .	8
Checkout & Troubleshooting . . . . .	10
LED Description . . . . .	12
Limiting Occupant Access . . . . .	12
User's Guide . . . . .	12

## Mounting

The SZ1018 are designed for wall mounting using two #6 sheet metal screws, either over a horizontally installed 2" x 4" junction box, or directly to block or drywall.

For best results, the thermostat should be mounted on an interior wall which reflects normal room environment, at a height of approximately five feet from the floor. Avoid areas exposed to direct sunlight, unusual heat or cool sources, open doors and windows, unventilated locations and hot or cold air from diffusers.

If using a remote room sensor, it should be mounted in the manner described above. The thermostat may then be mounted in an area which is accessible for adjusting its settings.



**Caution:** Remove power from thermostat prior to mounting.

# Wiring

The SZ1018 use standard terminal designations for wiring. See diagram below.

## REMOTE SENSOR WIRING

Use 18 AWG shielded twisted-pair grounded at the sensor mounting location. Sensor wiring runs of up to 250 feet are attainable if properly shielded wire is used and the installation environment is free of electrical noise. Sensor wire should be kept at least five feet away from line voltage wiring.

The SZ1018 accept two remote sensors. Consult the TS Series Temperature Sensor Submittal Data sheet for a complete listing of packaging and application styles. When using TCS Basys Controls three-wire sensors, use the black and red leads and either clip or twist off the white lead. Make sure that the dip switches are set for the sensors you are using.

## POWERING THE SZ1018

The SZ1018 are powered from 24 VAC +/- 20 %.

If wiring for communications, dedicated power must be used to power the SZ1018. Several S-series thermostats may be powered from the same transformer, provided that the transformer has sufficient power, although the polarity must be kept the same throughout because these are half-wave rectified devices. (SZ1018 thermostats require 8 VA @ 24 VAC).

When the SZ1018 are used as a stand-alone thermostat without communications, the unit transformer may be used to power it. However, using separate power will eliminate possible ground loops which may damage the thermostat.

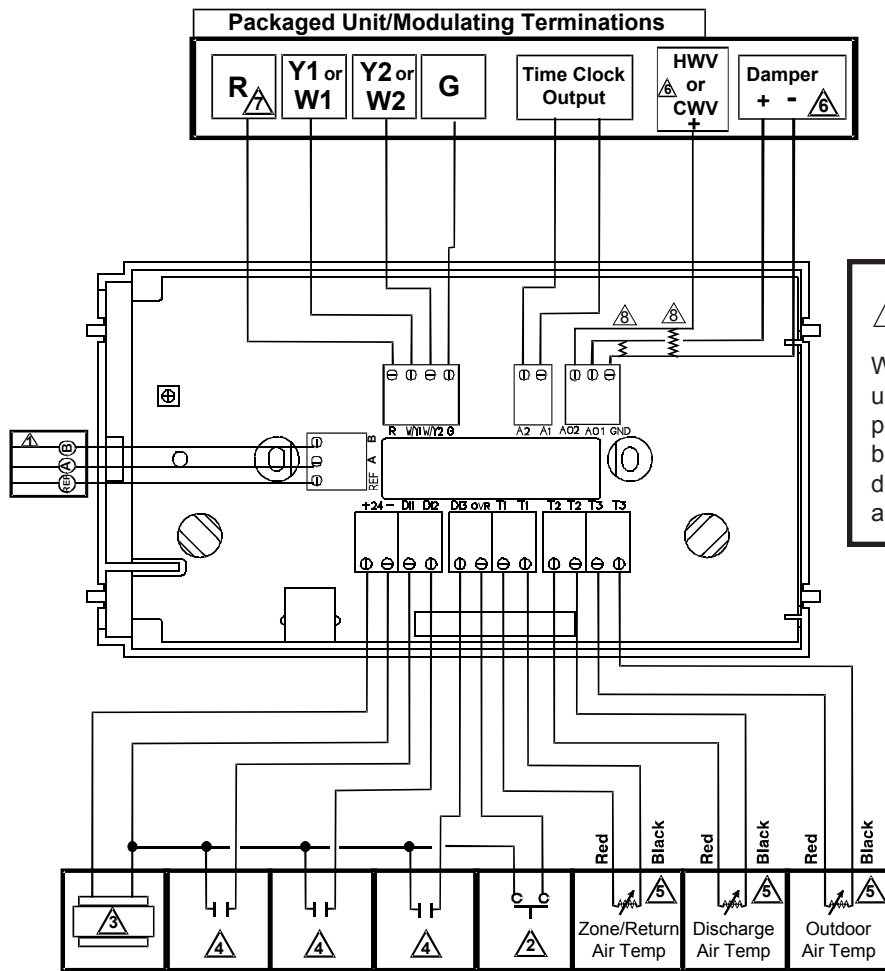

**CAUTION**

When multiple TCS devices are using a single transformer, the polarity of the power wiring must be maintained because all TCS devices are half-wave rectified and have common return paths.

- |  |   |  |
|--|---|--|
| <p><b>1</b> For communication wiring, use twisted, shielded 18 AWG. Must be run separately.</p> <p><b>2</b> Dry momentary contact. Must not be powered.</p> <p><b>3</b> 24 VAC transformer. See powering instructions.</p> | <p><b>4</b> Dry contact. Must not be powered.</p> <p><b>5</b> Sensor input wiring 18 AWG, twisted, shielded pair.</p> | <p><b>6</b> 4 to 20 mA output. 600 ohm max. Do not power actuator with power from the thermostat. The thermostats are half-wave rectified, whereby the power ground is common with the signal ground.</p> <p><b>7</b> Up to nominal 28 VAC from equipment transformer.</p> <p><b>8</b> Add 500Ω resistor (included in bag) to convert 0/4 to 20mA to, 0/2 to 10 VDC.</p> |
|--|---|--|

# Setup

**Note:** If using remote sensor(s), the calibration may need to be adjusted. See “Checkout and Troubleshooting” section.

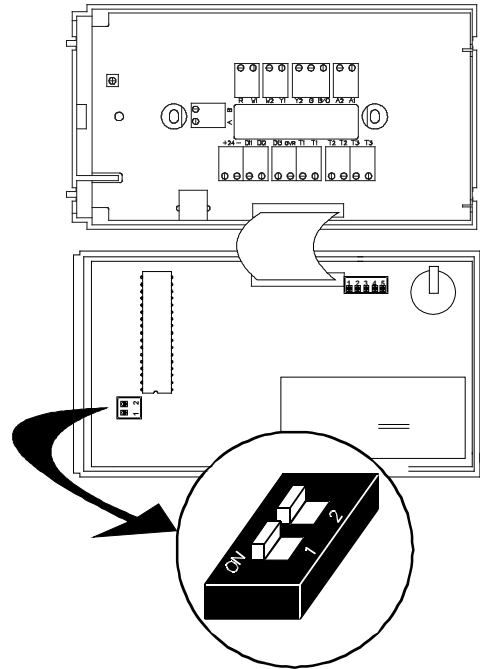
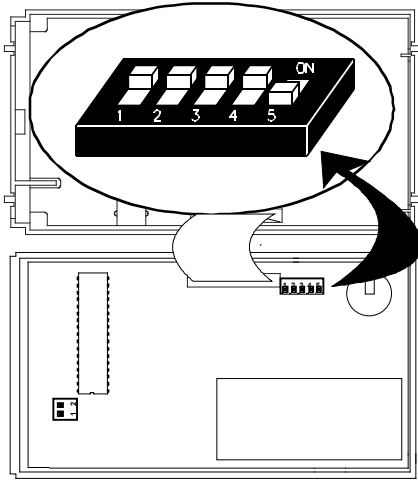

## SENSOR SELECTION

The dipswitches in the cover (shown above connected with ribbon cable) as well as the programming must be set when using remote room, discharge, and/or outdoor sensors. Use the following guide to determine the dipswitch settings for your application.

Using built-in room sensor only.  
(This is the default setting.)

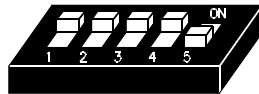

Using built-in room sensor with discharge air sensor only.

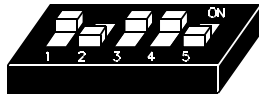

Using built-in room sensor with outdoor air sensor only.



Using built-in room sensor with both discharge and outdoor air sensors.



Using remote room sensor only.



Using remote room sensor with discharge air sensor only.



Using remote room sensor with outdoor air sensor only.



Using remote room sensor with both discharge and outdoor air sensors.

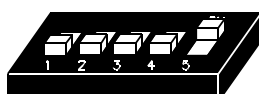

## KEYPAD ACCESS

The dipswitches in the cover (shown above connected with ribbon cable) must be set in order to lock the user out of programming and/or to set the clock and schedule. Use the guide below to set these dipswitches for your application. Otherwise, user access may be limited with an access code set in programming. (The fan and system switches are enabled or disabled in programming only, and require no dipswitch placement.)

Keypad access to both programming and clock setup. (This is the default setting.)

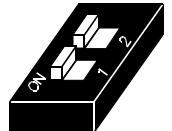

No keypad access to programming or clock setup.

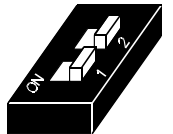

Keypad access to programming only.

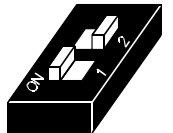

Keypad access to clock setup only.

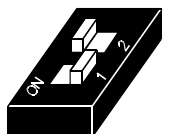

Once the dipswitches have been set and you have confirmed that the sensors are reading correctly (and program and clock setup are finished, if locking out access with dipswitches), secure the cover to the base with the two set screws located at the top right and the left side to prevent tampering.

# Programming

The SZ1018 may be programmed through the display and keypad, or with a PC.

If programming with a PC, the following must be set through the keypad prior to programming:

- Address (step #3)
- Temperature scale (step #4)

For more information on programming through the PC, consult your software manuals.

## PROGRAMMING THROUGH THE KEYPAD

To access the programming screens, press the program setup button. To make changes, use the warmer and cooler keys. Access may be locked out with dip-switches, or an access code may be required.

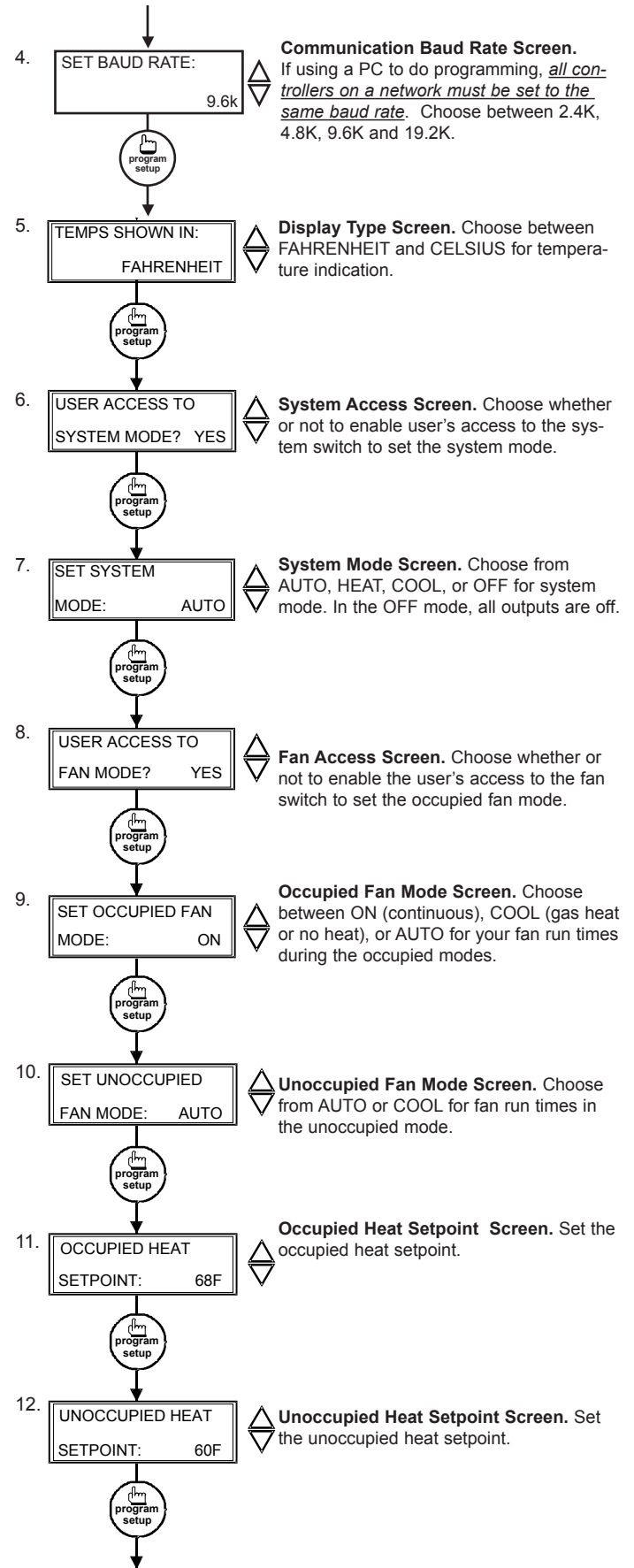
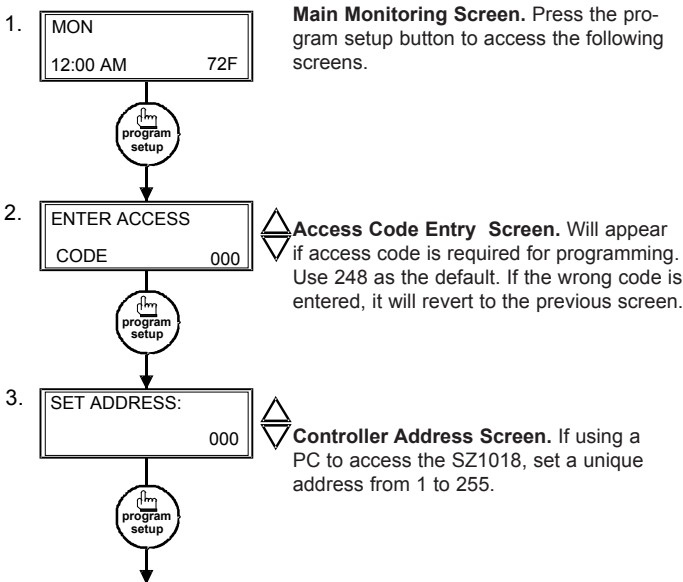
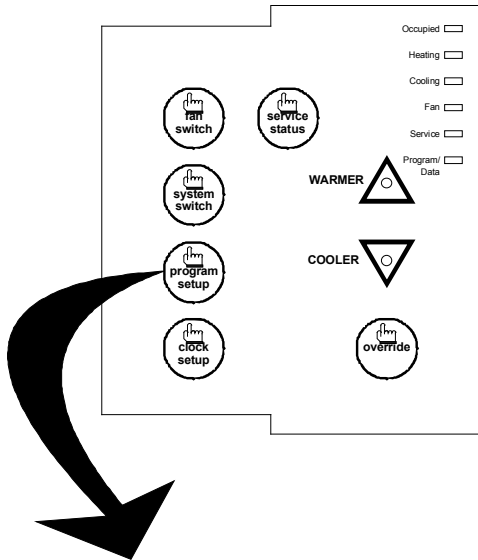

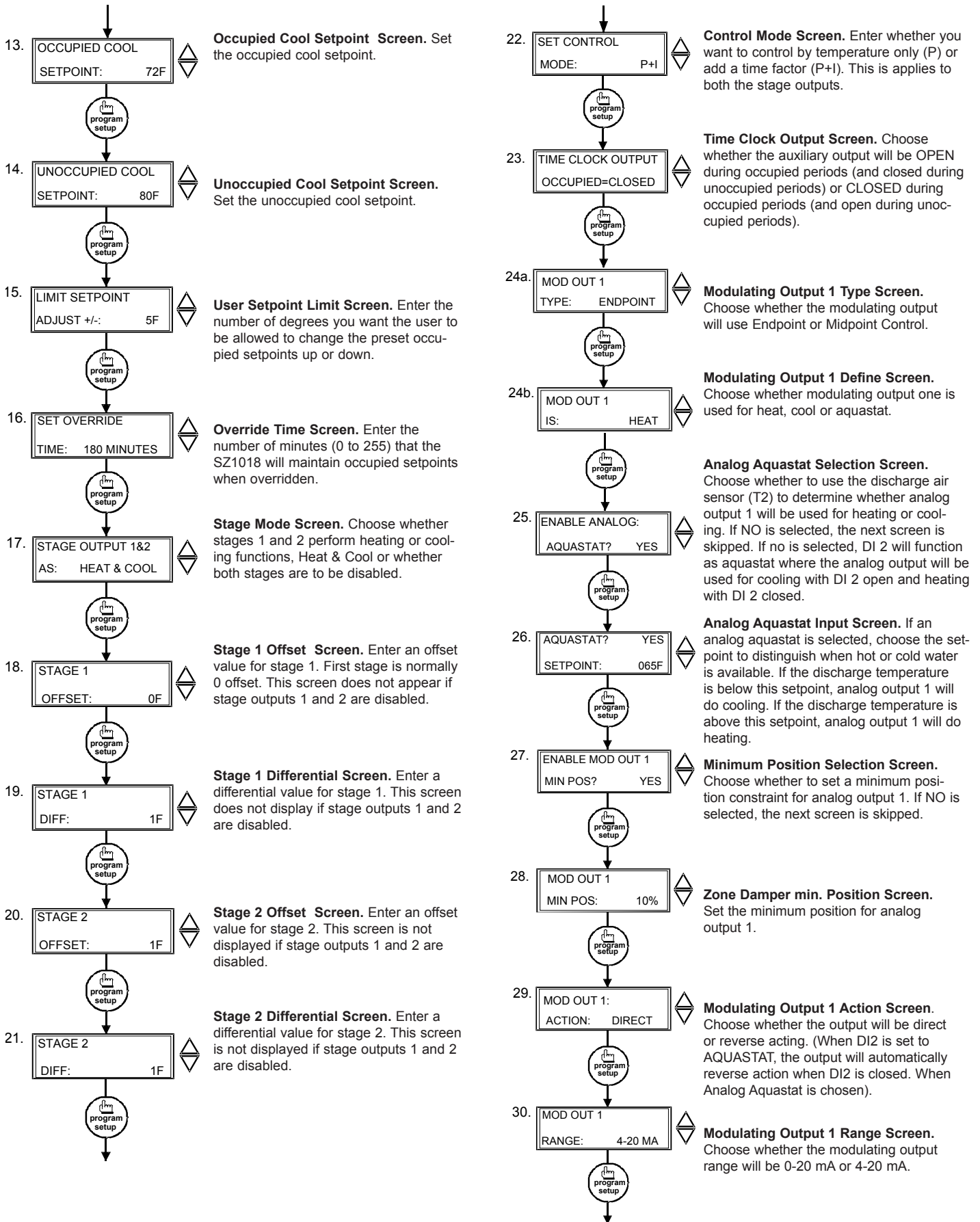

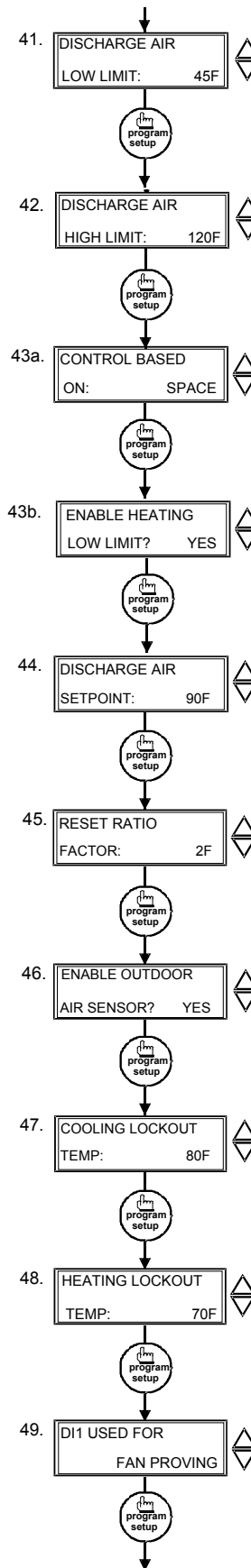
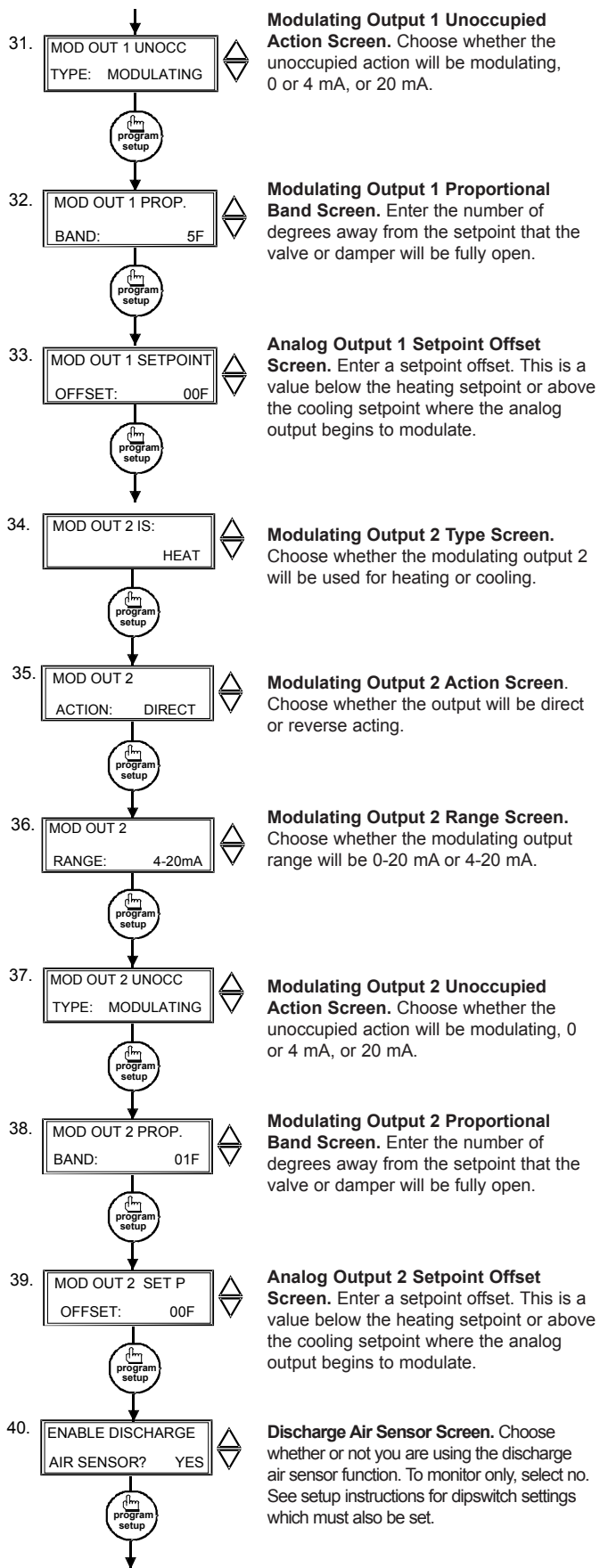

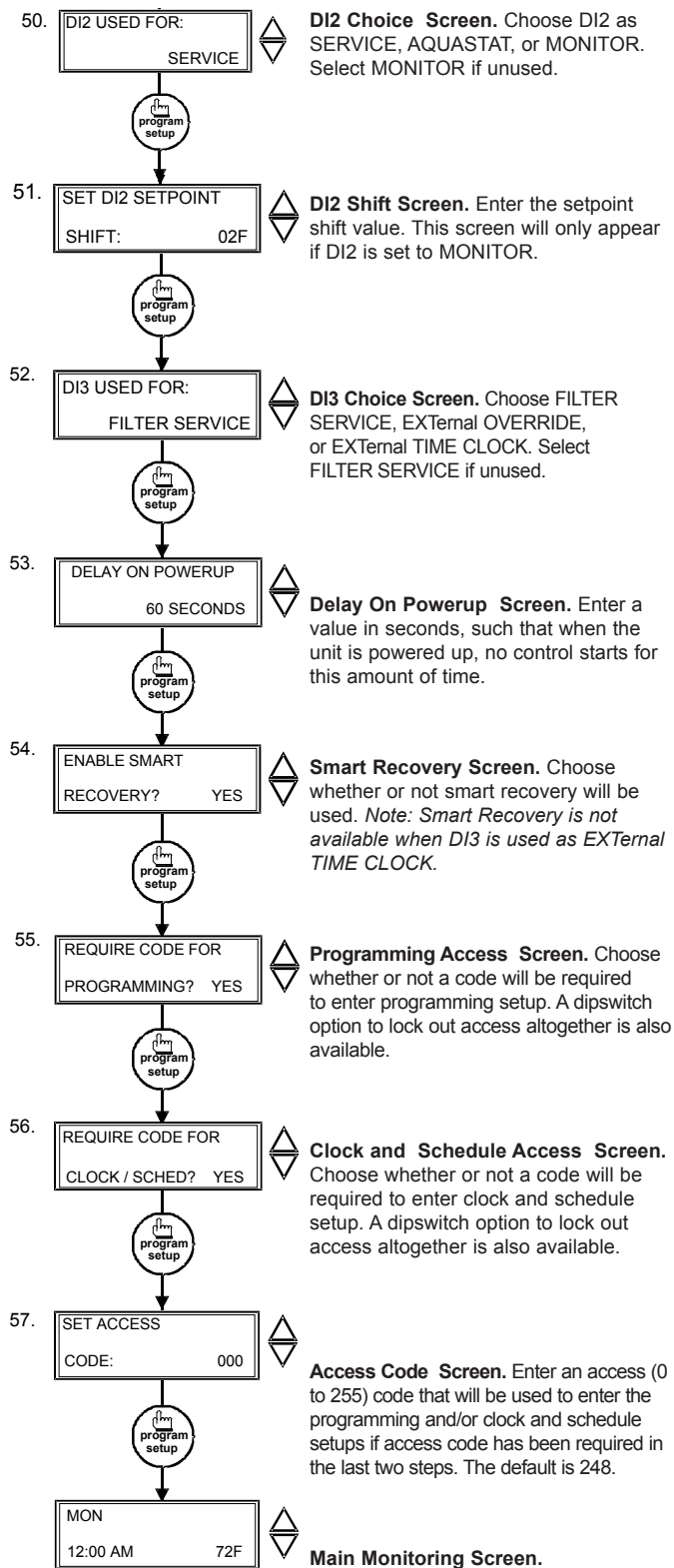

## Setting Clock & Schedule

The SZ1018 clock and schedule may be set through the keypad on the face, or with a PC. For more information on programming through the PC, consult your software manual.

### SETTING CLOCK & SCHEDULE THROUGH THE KEYPAD

To access the clock and schedule screens, press the clock setup button. To make changes, use the warmer and cooler keys. For screens that have more than one field to set, use the override key to move to the next field. Access may be locked out with dipswitches, or an access code may be required.

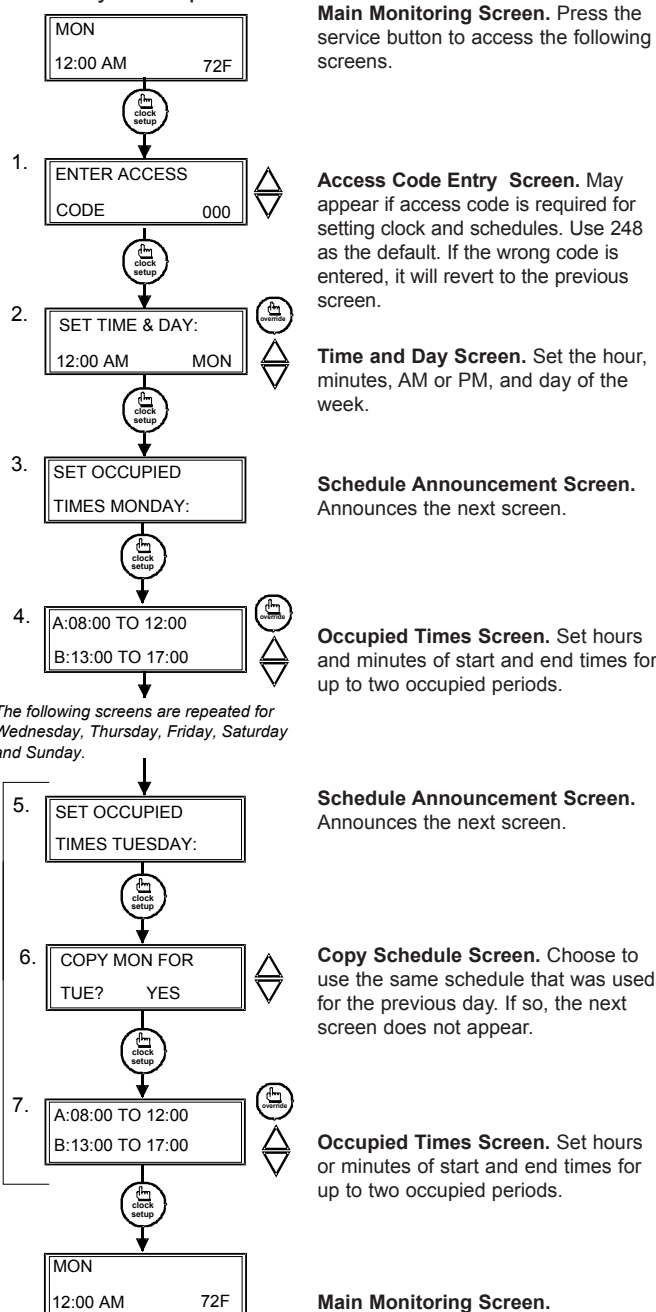

# Operation

## UNOCCUPIED SETBACK

The SZ1018 operate in either an occupied or unoccupied mode. During the occupied mode, the occupied heating and cooling setpoints will be maintained, and the fan will operate according to its occupied setting. During the unoccupied mode, the unoccupied heating and cooling setpoints will be maintained, and the fan will operate according to its unoccupied setting. The occupied LED will be lit when the unit is operating in the occupied mode.

The occupied schedule may be set utilizing the internal time clock or DI3 may be used with an external time clock, whereas when DI3 is closed, the unit is in the occupied mode. The Smart Recovery function is disabled when DI3 is used for external time clock.

## OVERRIDE

A timed override is available using the button on the face of the thermostat or through momentary contacts wired into the OVR terminal. The amount of time the unit will be overridden is set from 0 to 255 minutes in the programming screen. This override behaves differently depending on the mode the thermostat is operating in (occupied or unoccupied) and the options that have been enabled within the software.

In standard mode, the override only activates in unoccupied mode and takes the thermostat into occupied mode. If "Override for Occupied Period" is enabled using the software, the override also activates in occupied mode and takes the thermostat into unoccupied mode. In either case, you are able to view the time remaining in the override period both within the software and by using the service button to scroll through the status screens. If the occupant desires to return the thermostat to unoccupied or occupied operation (depending on how the override was used) before the override time remaining elapses, they may press the override button again.

Additionally, an "Override Hold" feature is built into the thermostats. When in unoccupied mode, pressing the override once and then pressing/holding it for 5 seconds puts the thermostat into a "hold" mode (the override LED on the thermostat will flash quickly to confirm the mode change). In this mode, the override setpoints are used until the next occupied period is reached or until the thermostat is manually taken out of the "hold" mode by pressing the override button again. This feature also works when the "Override for Occupied Period" is enabled BUT starting from the occupied mode and holding the thermostat in the unoccupied state.

A continuous override is available through the DI3 contact or the software. If DI3 is set to external override, the unit will be in the occupied mode whenever the DI3 contact is closed. When using this option, the timed override may still be activated.

## SETBACK AND OVERRIDE APPLICATIONS

In most applications, it is desired to maintain a regular schedule, and allow timed override with the button on the face or with a remote momentary contact.

To allow a regular schedule, and also automatically override with the use of occupancy or light sensor, set DI3 to override and set it up so that the contact is closed when you want the override.

For applications where a room might not be used on a regular schedule, such as conference rooms, set DI3 to time clock and close the contact when you want the room occupied, such as with a switch or wind-up timer. If each occupancy period is about the same, (theaters, meetings) another option is to set the DI3 to time clock, and use the timed override button to put the unit in occupied mode.

To make the unit always occupied, set DI3 to time clock and short the DI3 terminal to ground.

## DISCHARGE AIR TEMPERATURE SENSING

The SZ1018 accept a remote 1000  $\Omega$  discharge air sensor (TS1009 or TS1002) for monitoring purposes. (See setup instructions for dipswitch placement for this option.)

Choose YES in programming screen #39 only if you are using a discharge air sensor and you want to enable the discharge air temperature high and low limit functions or discharge air reset function. See Discharge Air Reset section for further programming options. If NO is chosen, the discharge air is still monitored.

When the function is enabled, a LOW LIMIT and HIGH LIMIT are entered in steps #40 and #41. If the HIGH LIMIT is reached, the fan and heating stages will be turned off and will remain off until the discharge air temperature falls 3° below that limit. If the LOW LIMIT is reached, the fan and cooling stages will be turned off and will remain off until the discharge air rises 3° above that limit. When either limit is reached, the service LED will be on until normal operation resumes.

The SZ1018 can use a remote discharge temperature sensor for changeover from heating to cooling based on the ANALOG SETPOINT set in step #25.

The discharge air span is 0 to 150 °F (-17.8 to 65.6 °C).

## ANALOG OUTPUT / DISCHARGE AIR RESET

The analog output on the SZ1018 are used to control the heating or cooling in a space. To use the discharge air reset function, a discharge air sensor must be installed. In programming step #30, the discharge air sensor must be enabled. In programming step #42, the control must be based on DISCHARGE air.

### (Do not use with Zoning System)

In programming screen #43, you are asked to enter a discharge air setpoint. The discharge air temperature will be controlled to this setting by modulating the heating or cooling device.



In programming screen #44, you are asked to enter a reset ratio factor. This is the number of degrees that the discharge air setpoint is raised when the room temperature falls below the heating setpoint by 1 degree if the analog output is set for heating, or the number of degrees that the discharge air setpoint is lowered when the room temperature rises above the cooling setpoint by 1 degree if the analog output is set for cooling.

### OUTDOOR AIR TEMPERATURE SENSING

The SZ1018 accept a remote 1000 Ω outdoor temperature sensor (TS1003) for monitoring purposes. (See setup instructions for dipswitch placement for this option.)

Choose YES in programming screen #45 only if you are using an outdoor air sensor and you want to enable the outdoor air heating and cooling lockout functions (Do not use with Zoning System). If NO is chosen, the outdoor air is still monitored.

When the function is enabled, a COOLING LOCKOUT TEMP and HEATING LOCKOUT TEMP are entered in steps #46 and #47. If the outdoor temperature falls below the COOLING LOCKOUT TEMP, all cooling stages will be locked out and will remain locked out until the outdoor air temperature rises 2° above the lockout temperature. If the outdoor temperature rises above the HEATING LOCKOUT TEMP, all heating stages will be locked out and will remain locked out until the outdoor air temperature falls 2° below the lockout temperature.

The outdoor air span is -40 to 160 °F (-40.0 to 71.1 °C).

### FAN PROVING

The SZ1018 allow DI1 to be set for fan proving to protect equipment on fan failure. To utilize this, a pressure or current switch is required, which indicates when the fan is running. If the thermostat turns on the FAN, and DI1 is not closed after thirty seconds, the system will go to OFF, disabling all outputs, the fan LED will turn off, and the service LED will be lit until the system is manually reset by switching the system to a mode other than OFF.

### DI2 SETPOINT SHIFT

The SZ1018 allow DI2 to be set for setpoint shift for energy demand setback. This is enabled by setting DI2 to the MONITOR mode. A digital contact that closes when setback is needed should be wired into DI2. You may specify a number of degrees such that, when the thermostat is operating in the occupied mode, and DI2 is closed, the heating setpoint will be lowered this number of degrees, and the cooling setpoint will be raised this number of degrees. The fan will continue to operate according to its occupied setting. If you are using DI2 as monitor for another purpose, make sure to set the setpoint and shift value to zero.

### STAGE OUTPUT PARAMETERS

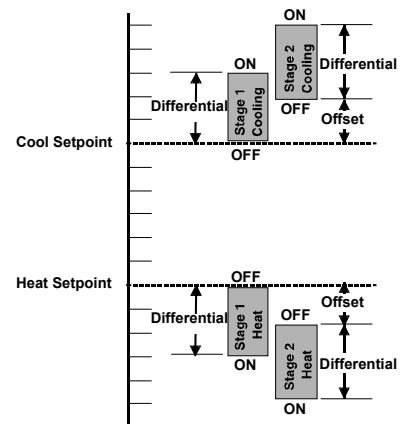

The SZ1018 will control up to two stages of either heating or cooling.

For each stage, you may specify an offset and a differential value. The offset value is the amount away from the setpoint a stage will turn off. By assigning a stage a value other than zero, you “anticipate” that the residual heat or cooling in the duct or the other stages will bring the temperature back to setpoint. In most cases, the first stage is set to zero. The differential value is the difference between the on and off points.

### ANALOG OUTPUT PARAMETERS

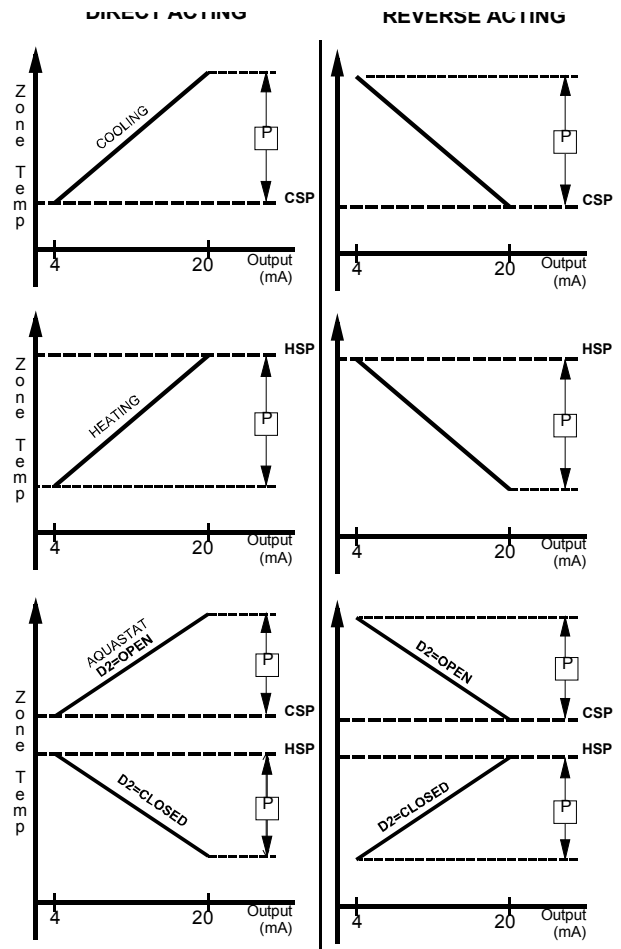

Use programming steps #28 through #32 to program the operating parameters for analog output 1. Use programming steps #33 through #38 to program the operating parameters for analog output 2.

Select whether the analog output is set for heating, cooling or aquastat. Select direct or reverse action. Select whether you want the analog output to modulate from 4 to 20mA or 0 to 20mA. Select the unoccupied action ("20mA or 0 / 4mA" will hold the analog output device open or closed during unoccupied times. "Modulating" will modulate the analog output device to maintain the unoccupied heating or cooling setpoint.). Enter a proportional band (throttling range) in degrees.

### P+I OPTION

The SZ1018 also have a P+I option. Without enabling this option, stages turn on and off based on temperature vs. setpoint alone, as described above. By enabling this option, you add a time factor to anticipate heating and cooling.

### DI2 AQUASTAT

DI2 may be set as an aquastat function. When DI2 is selected to have an aquastat function, and the analog output is selected to have an aquastat function, operation is as follows.

With DI2 "Open", the analog output operates in cooling mode, and uses selected direct or reverse action. When DI2 is "Closed", the analog output operates in heating mode, and uses the opposite of the selected direct or reverse action.

### SMART RECOVERY

"Smart Recovery" may be enabled. It ramps the setpoint 4°F/hr. when going from the unoccupied mode to the occupied mode. At the beginning of the occupied mode, the occupied setpoint will be reached, many times without the need for the second stage to come on. This feature is automatically disabled when DI3 is set to external time clock.

### BUILT-IN DELAYS

The SZ1018 have delays built into the programming sequences to protect equipment. The fan has a minimum on and off time of 30 seconds. When the fan is in AUTO or COOL mode, it will come on 30 seconds before the heating or cooling stages are allowed to sequence on, and remain on for 30 seconds after the heating or cooling stages sequence off. Each stage has a minimum on and off time of two minutes. There is a minimum of two minutes between when one stage turns on until the next stage is allowed to turn on, as well as when one stage turns off until the next stage is allowed to turn off.

### DELAY ON POWERUP

The SZ1018 have an adjustable delay on powerup. When several thermostats are used at one location, and the power goes out, most thermostats turn all of the units back on at the same time on regain of power, creating a peak. The thermostat allows you to set a value, in seconds, where no outputs are allowed to

turn on for that length of time on powerup. Setting each unit to a different delay allows you to soft start your system, and thus prevent this peak.

## Checkout & Troubleshooting

### CHECKOUT

*Note:* The fan has a minimum on and off time of 30 seconds. The heating and cooling stages have a minimum on and off time of 2 minutes.

You may verify the status of heating and cooling stages and fan in monitoring screens 5, 6, and 7, which are accessed by pressing the SERVICE STATUS button.

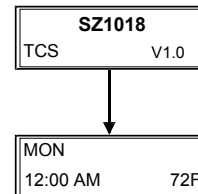

1. Verify all wiring prior to powering the thermostat.
2. Turn power on. The thermostat will display a momentary screen with the model number, and then the main monitoring screen with the time, day and current temperature.
3. Press the PROGRAM SETUP button until you reach the screen # 14 which allows you to set the occupant setpoint adjustment limits. Change this to +/-20 °F (11.1 °C). Press the PROGRAM SETUP button once more to store the change. Then press the SERVICE STATUS button once to exit the programming.



4. Press the FAN SWITCH button to access the fan mode and change the mode to AUTO. Press the FAN SWITCH button once more to store the change. Press the SYSTEM SWITCH button to access the system mode and change the mode to AUTO. Press the SYSTEM SWITCH button once more to store the change.
5. Verify that the thermostat is operating in the occupied mode by making sure that the top LED is lit. If not, press the OVERRIDE button. The LED should light up.
6. Take note of the current temperature reading. Press the WARMER (up) button. The setpoint adjustment screen should now be showing. Press the WARMER button until the heating setpoint is greater than the current temperature by at least five degrees. The fan will come on. The heating stage(s) will sequence on after 30 seconds.
7. Press the cooler (down) button until the heating setpoint is one degree less than the current temperature. The heating stage(s) will sequence off. The fan will turn off 30 seconds after the last heating stage.

8. Press the cooler button until the cooling setpoint is less than the current temperature by at least five degrees. The fan will come on. The cooling stage(s) will sequence on after 30 seconds.
9. Press the warmer button until the cooling setpoint is greater than the current temperature by one degree. The cooling stage(s) will sequence off. The fan will turn off 30 seconds after the last cooling stage.
10. Take note of the room (and discharge) air temperatures. If the analog output is set for Cooling, press the Cooler button until the cooling setpoint is less than the current room temperature by at least 5°. The cooling device should start operating. If the analog output is set for Heating, press the Warmer button until the heating setpoint is greater than the current room temperature by at least 5°. The heating device should start operating.
11. Go back to programming step #14 and set the setpoint adjust limit back to the desired value. Make any other changes in programming, clock, and schedule. Set the fan and system modes to their desired settings.
12. If using remote sensors, verify that the reading is correct. If not, see *Wrong Temperature Display* in "Troubleshooting" section.

## TROUBLESHOOTING

### No Display

Check for 24 VAC on terminals "+24" and "-24". Check the cable connecting the cover to the base for a good connection.

### Fan Does Not Come On

The fan is on whenever the fan LED is on. If the fan should be on, but the fan LED is off, check the fan and system switch modes, and the unoccupied fan mode in programming. If the fan is off but the fan LED is on, check wiring. Short terminals "R" to "G" and see if the fan comes on. This is a check for a mechanical relay failure.

### Heating or Cooling Does Not Come On

At least one stage of heating is on whenever the heating LED is on, and at least one stage of cooling is on whenever the cooling LED is on. If heating or cooling should be on but the heating or cooling LED is off, check the fan and system switch modes. Also, check the heating and cooling setpoints, offsets and differentials, and the room temperature to be sure heating or cooling should be on. If using outdoor air heating and cooling lockouts, or discharge air high and low limits, check their values to be sure heating or cooling is allowed. If heating or cooling is off, but the corresponding LED is on, check the wiring. Short terminals "R" to "Y/W1" or "Y/W2" and see if the heating or cooling comes on. This is a check for a mechanical relay failure.

## Wrong Temperature Display

Initially, verify the wiring connections to check for problems (poor connections, opens, or shorts). If the temperature is at a minimum or maximum reading, check that the sensor dipswitch positions are correct as shown in the Setup section of this document. Also, verify the resistance reading for the sensor in question. A remote sensor should read 1080 to 1090 ohms at room temperature. The built-in sensor should read 108 to 109 ohms at room temperature. If any of the temperatures are still reading slightly high or low, you can add in a temperature offset (calibration) using Ubiquity or TCS Insight. In Ubiquity, you can edit the calibration offset for each temperature input (room, discharge, outdoor air, etc.) on the controller's programming page. For example, if the room temperature is reading 2 degrees high, you would subtract 2 from the existing offset in the room temperature calibration offset field and submit the page. In TCS Insight, the process is similar. Refer to the Calibrate Using TCS Insight Tech Bulletin # 1019 for details. As a last resort and only when directed to do so by TCS technical support, you may be able to use the on-board adjustment pots. Refer to the Thermostat Sensor Calibration Tech Bulletin # 1005 for details.

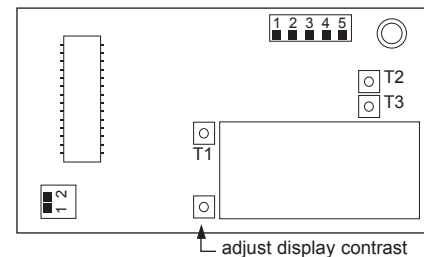

### Service LED is On

If the service LED is on, it may be for monitoring purposes or it may indicate a critical problem. The first monitoring screen accessed by pressing the service status button will display why the light is on.

### Outputs Will Not Shut Off

First check the room temperature and the setpoints and determine whether the output should be on. There are delays and minimum on and off times for the fan and heating and cooling stages. Also, check the service status menus to verify that the outputs are on. Turning the system to "off" will instantly turn all outputs off. The thermostat can be reset by pressing the system switch button and the service status button simultaneously.

### Analog Output Not Working Properly

Check wiring. A separate transformer should be used for the SZ1018 and a separate transformer should be used for the damper motor(s). Check to make sure that the analog output is programmed correctly.

Check the Service Menu. The Mod Out Screen will tell

you what the SZ1018 are trying to put out for an output. Compare this with the actual position of the heating or cooling device.

## SERVICE SCREENS

Through repeated pressing of the SERVICE STATUS button, the service screens (shown here) are displayed, which enables you to monitor various functions of the Superstat.

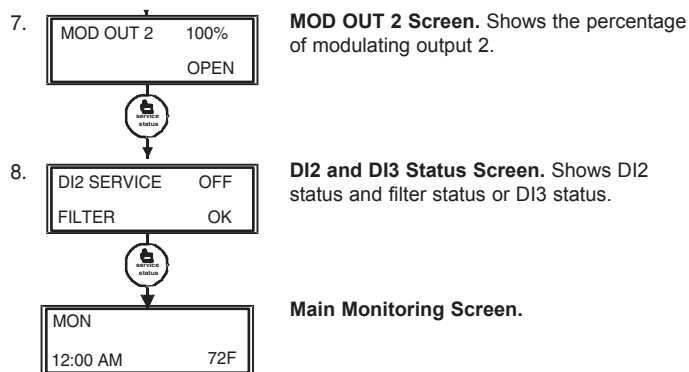
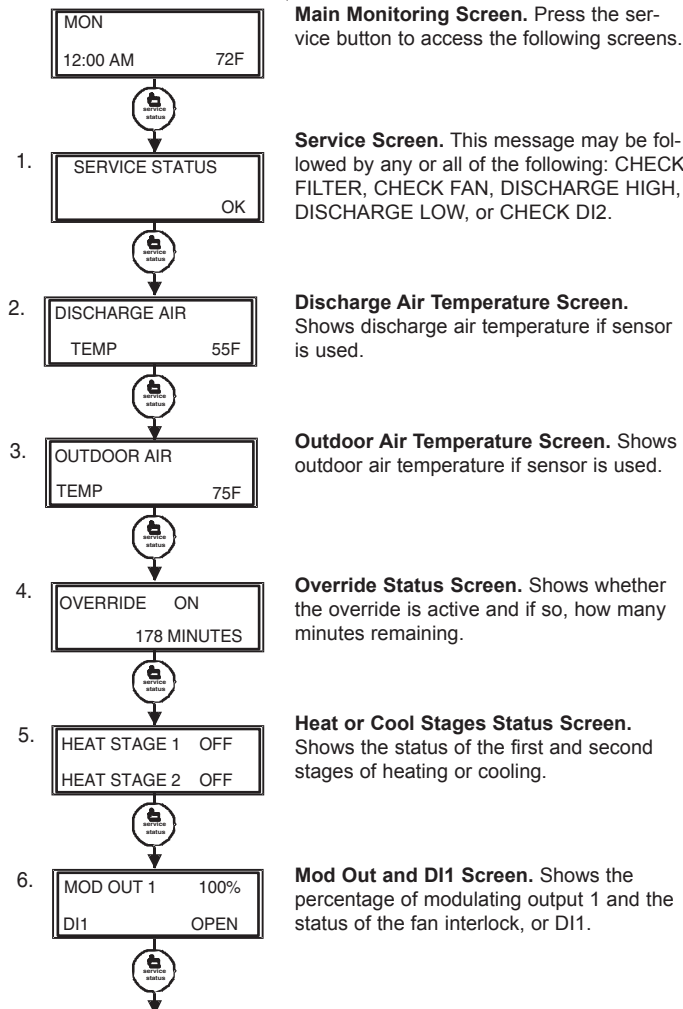
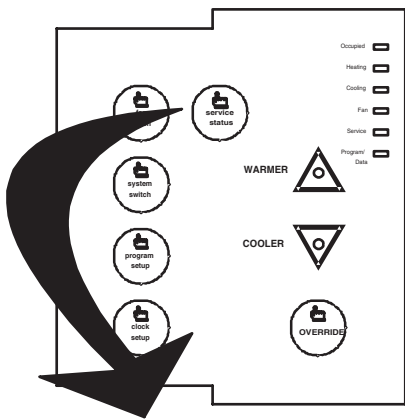

## LED Description

Six LEDs on the face allow the occupant to view the current operating status of the thermostat.

### OCCUPIED

This LED will be lit whenever the unit is operating in the occupied mode.

### HEATING

This LED will be lit when any heat output is on.

### COOLING

This LED will be lit when any cooling output is on.

### FAN

This LED will be lit when the fan output is on.

### SERVICE

This LED will be lit when the high or low discharge air limit has been reached, when the fan interlock has indicated failure, or when the filter service or service input are closed.

### PROGRAM/DATA

This LED will be lit when the thermostat is within the programming or clock setup menus. It will blink when the unit is being accessed by a PC.

Additional monitoring is available by continually pressing the service key.

## Limiting Occupant Access

### SETPOINT ADJUSTMENT

The occupant may temporarily change the occupied heating and cooling setpoints +/- 5°F by factory default. This setpoint change will remain until the end of the current occupied period, at which time the program reverts to the setpoints defined in programming. To change the range of adjustment allowed, see programming step # 14.

### OVERRIDE

The occupant has the ability to put the unit into occupied mode by pressing the override button on the front. By factory default, the unit will remain in the occupied mode for 180 minutes. This value may be changed

from 0 to 255 minutes in programming step # 15.

### **FAN SWITCHING**

The option to allow the occupant to change the occupied fan mode is allowed by factory default. To lock out access to fan switching, see programming step #7.

### **SYSTEM SWITCHING**

The option to allow the occupant to change the system mode is allowed by factory default. To lock out access to system switching, see programming step #5.

### **SETTING CLOCK & SCHEDULE**

The ability to set the clock and schedule is allowed by factory default. An access code may be required as set in programming step # 44, or access may be denied altogether using dipswitches described in the setup section.

### **PROGRAMMING**

The ability to program control parameters is allowed by factory default. An access code may be required as set in programming step # 43, or access may be denied altogether using dipswitches described in the setup section.

## User's Guide

Inside the hinged door of the thermostat is the Superstat™ User's Guide. This guide is designed to assist the installer in explaining to the end user how to operate their new thermostat, as well as serve as a handy future reference for the end user.

We recommend that the installer fill out pages 1, 5, 7 and 8 (where applicable) and explain to the user how the thermostat operates, what settings may be changed, and how the time clock schedules are used.

