

Model#: **EM-24A2**

Exterior Photocell

Installation Instructions

The EM-24A2 is a low voltage photocell used for operating exterior lighting. It is used for signaling light levels to Watt Stopper lighting control panels that are controlling exterior lighting.

- Typically the EM-24A2 is mounted on the exterior or roof of a building with the light level window facing north.
- The EM-24A2's 1/2" threaded male conduit base can be connected to conduit fittings or to junction boxes with the supplied locknut.
- Connect 24 VAC to the two black wires. Normally, this power is supplied from the lighting control panel the photocell serves.
- The relay contact red wires are connected to the lighting control panel or to a low voltage controlled load.

Mounting and Wiring

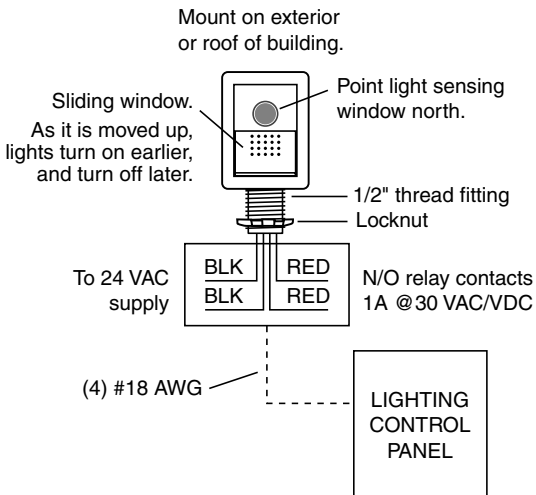

Technical Support:

1(800)879-8585 1(972)578-1699

01052r1 4/00



CES/O APPLICATION NOTE

ENERGY MANAGEMENT SYSTEM

A building energy management system needed to control outdoor security and safety lighting. The lighting systems were required to turn on and off at different light levels using the building energy management system.

Photocells and mechanical timers were considered, but didn't provide the precise switching level controls required. The mechanical timers didn't allow for easy changes in schedules and daylight/standard time changes.

The **PLC-MULTIPOINT CES/O SENSOR** provided the energy management system with the lighting level signal required to control the outdoor safety and security lighting. The sensor was powered by the energy management system's 12VDC power supply source. The sensor signal provided a linear light level input into the energy management system. The **CES/O SENSOR'S** input range was set at 750 FC and the output was 0 to 10VDC providing a resolution of 13.3mv/FC or (75 FC/V) which was sufficient for the energy management system to control the lighting levels.

The ON and OFF switching setpoints were entered into the energy management system via the operator terminal. The minimum Hold-On-Time, transient filtering and output control was all handled through the energy management system. All of the above were displayed on the operator terminal, including the current light level from the **CES/O SENSOR**.

APPLICATION NOTES

