



TCS/1000 Series

Matched and Unmatched
Temperature Transmitters

Description

The TCS/1000 Series are temperature sensor and transmitter pairings designed for sensing temperature in a variety of applications. The T4 and T5 sensors are matched calibrated sets while the T2 and T3 are not.

The TCS/1000 Series features:

- 4-20 mA loop-powered transmitters
- Certified calibrated matched sets (T4 and T5)
- 100 Ω or 1000 Ω platinum RTD's
- A variety of factory calibrated ranges

Specifications

General

Sensing element: T2 & T4: 100 Ω Platinum RTD
T3 & T5: 1000 Ω Platinum RTD
Transmitter accuracy: +/- 0.1% of span
Sensor accuracy: PtRTD: +/- 0.1% @ 32°F (0°C)
Averaging: +/- 1.0°F @ 70°F (21.11°C)
Zero and span adjustment: Non-interacting

Environmental

Operating temperature:
Transmitter: 32 to 158°F (0 to 70°C)
Sensor: -50 to 375°F (-45.56 to 190.56°C)
Operating humidity: 0 to 100% RH, non-condensing
Storage temperature: 14 to 176°F (-10 to 80°C)

Electrical

Supply voltage: 8 to 35 VDC
Input voltage effect: +/- .001% of span/volt
Output: 4 to 20 mA DC, 2-wire
Maximum over current: 25 mA
Radio frequency interference effect:
+/- 0.5% FSO @ 27 MHz
Electromagnetic interference effect: +/- 0.1% FSO
Polarity protection: Diode protected

Specifications subject to change without notice

Ordering Information

Part #	Description
TCS/1000-T2 or T3	Temperature transmitters with PtRTD temperature sensors
TCS/1000-T4 or T5	Temperature transmitters matched with PtRTD temperature sensors

(specify temperature range and mounting configuration at time of ordering)

T4 or T5 Accessories

TQ1104	4" Thermowell, stainless steel to be used with 4" or 8" duct mount sensor
TQ1110	8" Thermowell, stainless steel to be used with 4" or 8" duct mount sensor
CP1030	Regulated power supply
QE50	100Ω PtRTD simulator
QE51	1000Ω PtRTD simulator

Dimensions

Note: inches [mm]

Outdoor Mount Sensor

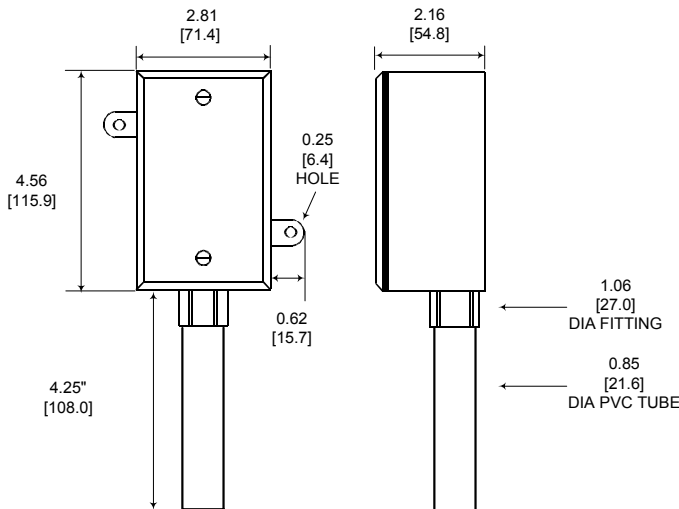

Wall Mount Sensor

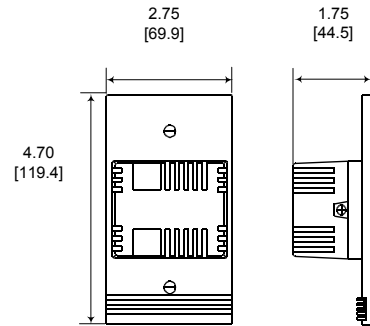

Immersion Mount Sensor

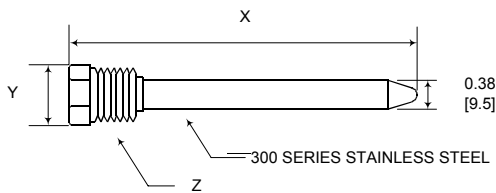

X: 6.75" OR 4.88" LENGTHS AVAILABLE
 Y: 1.13" FOR 6.75" IMMERSION
 0.88" FOR 4.88" IMMERSION
 Z: 0.75" NPT FOR 6.75"
 0.50" NPT FOR 4.88"

Pipe Strap-on

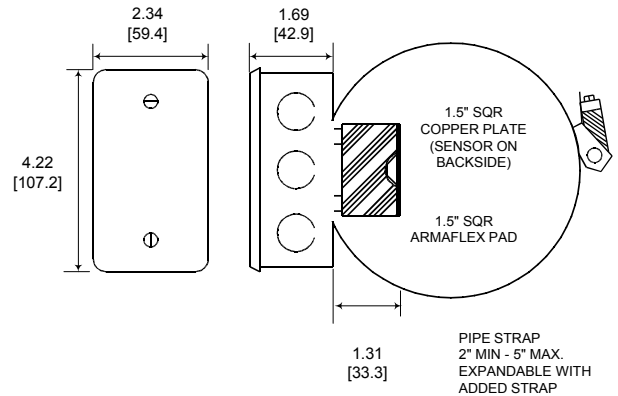

Dimensions

Note: inches [mm]

4" or 8" Duct Mount Sensor

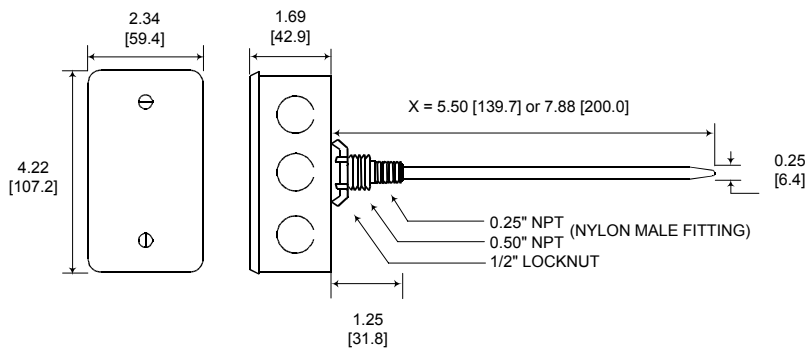

Averaging Mount Sensor

